

TBS Ltd

Specification for inbound deliveries

PLEASE DESTROY ALL PREVIOUS COPIES

INDEX		Page
A	GOODS IN SPECIFICATION FOR TBS FRATING	
1.0	INTRODUCTION	3
2.0	BOOKING-IN	3/4
3.0	PRODUCT IDENTIFICATION	4
4.0	BINDER'S PACKS	5
5.0	LICENCE PLATE	6/7
6.0	PALLETS	8
7.0	DELIVERY VEHICLES	9
8.0	POINT OF SALE	9/10
9.0	HEALTH AND SAFETY	10
10.0	GENERAL	11
B	SITE ADDRESSES	12
C	TBS PALLET POOL PARTICIPANTS	13
	APPENDIX 1: PALLET SPECIFICATION	14
	APPENDIX 2: BINDER'S PACK IDENTIFICATION REQUIREMENTS	15
	APPENDIX 3: SCHEDULE OF RATES	16
	ISSUES SHEET	17
	APPLICATION FOR TBS PALLET POOL	18
	APPENDIX 4: BOOK INDUSTRY COMMUNICATION SPECIFICATION (As separate document attached)	

A GOODS IN SPECIFICATION FOR TBS FRATING

1.0 INTRODUCTION:

- 1.1 The following Goods In Specification has been produced in order to ensure inbound product into TBS can be processed through the Goods In procedure efficiently, effectively and safely.
- 1.2 The Specification is based on health and safety and TBS specific requirements which comply with the TBS computer systems, warehouse operational procedures and the racking configuration.
- 1.3 It is necessary to adhere to the entire Specification. If the Specification is not adhered to it will cause delays, increase the possibility of errors and in some cases cause deliveries to be rejected. Where the Specification is not adhered to penalties may be imposed. (See 1.5 below).
- 1.4 It should be emphasised that Point of Sale should follow the same guidelines as those for Binder's Packs and that the extent of the POS section is due to the diversity of the range of product involved.
- 1.5 Where the Specification is not adhered to the cost of rectifying non-conformance will be recovered from the Publishers who may, in turn, wish to pass on these costs. There will be a £150 standard charge, plus operational costs based upon TBS's standard rates. (See Appendix 3 for Schedule of rates).

2.0 BOOKING-IN

- 2.1 All loads to be delivered must be booked in preferably 48 hours and at least **24 hours** in advance with our Goods In Department by telephone on **01206 255804**.
- 2.2 Inbound supplier delivery documentation should detail:
 - publisher • impression number • quantity per pallet
 - title • pack quantity • number of pallets
 - ISBN • number of packs • special instructions
 - price • total quantity • carrier
 - country of origin • vehicle type – whether rear or side unloading.
- 2.3 Delivery documentation must be sent to the Goods In department 24hrs in advance of delivery via fax or e-mail at the time of delivery.

Email address: goodsin@tbs-ltd.co.uk.

Fax: 01206 255848

- 2.4 All booked in shipments will be given a reference number and time slot at the time of booking in, which we require to be clearly written on the delivery note documentation for ease of identification by TBS.
- 2.5 Loads arriving early may be made to wait until their allotted time slot and vehicles arriving late may have to wait until the next available time slot. Late deliveries may be refused and will have to re-book.
- 2.6 Normal operating hours are: 06.00 to 16.00 Monday to Friday.
- 2.7 On receipt, goods will be checked for pallets delivered only. Any signatures provided will only confirm the number of pallets received, unexamined. Any shortages or variation will be notified in writing to Publisher and Printer within three working days of receipt.

3.0 PRODUCT IDENTIFICATION

- 3.1 TBS has adopted the BIC Standard for Binder's Pack Identification (See Appendices 2 and 4). Printers should note that our internal systems utilise the information contained within the BIC Barcode to populate the Title Master files relating to the product.

Codes that are incorrect or that cannot be read by scanning equipment will be rejected. TBS may be able to offer the facility to re-label incorrect pack labels. Such activity will be charged according to the TBS Schedule of Rates. (See Appendix 3).

- 3.2 TBS has on site bar code verification equipment and will be pleased to assist in defining the reasons for failure of bar codes. For further information please contact our Logistics Department on 01206 255757.

3.3 Labels must be placed and visible on at least one vertical side, not on the top of

3.4 The binder's label pack. should display the following information

- publisher's name
- printer's name
- publisher's purchase order number
- quantity in binder's pack
- ISBN in its standard form
- book title
- price/currency
- weight of pack
- A BIC standard barcode

3.4 The BIC Barcode should display within it:

- ISBN in its standard form
- quantity in binder's pack
- price

4.0 **BINDER'S PACKS**

- 4.1 All stock to arrive as full binder's packs. No loose copies or single copies on pallets will be accepted. TBS reserves the right to dispose of loose copies that are delivered.
- 4.2 Titles must be packed in consistent pack sizes as specified by the publisher.
- 4.3 Pack dimensions must not exceed 580mm x 420mm x 180mm.
- 4.4 Packs must not weigh in excess of 16 kg and the weight must be clearly displayed on the pack.
- 4.5 TBS expect all inbound products to be securely packaged to prevent damage and to be properly labeled for identification purposes. Where shrink-wrap film is used it should be of at least 65 microns gauge and opaque.
- 4.6 Preferred packaging for inbound product is 150K/150T B/C Flute Double Walled cartons. All types of wrap and cartons should fit the product appropriately. Product should be packaged without voids, so as to limit movement and avoid damage.
- 4.7 Binder's packs with gaps in the wrapping or contained in non opaque wrapping which in the opinion of TBS Quality Department will allow Ultra-Violet light to cause product deterioration, may either be rejected at the time of delivery or after at our detailed Goods In checking process. Cardboard inserts can be used over the gaps to avoid such deterioration. See picture below.

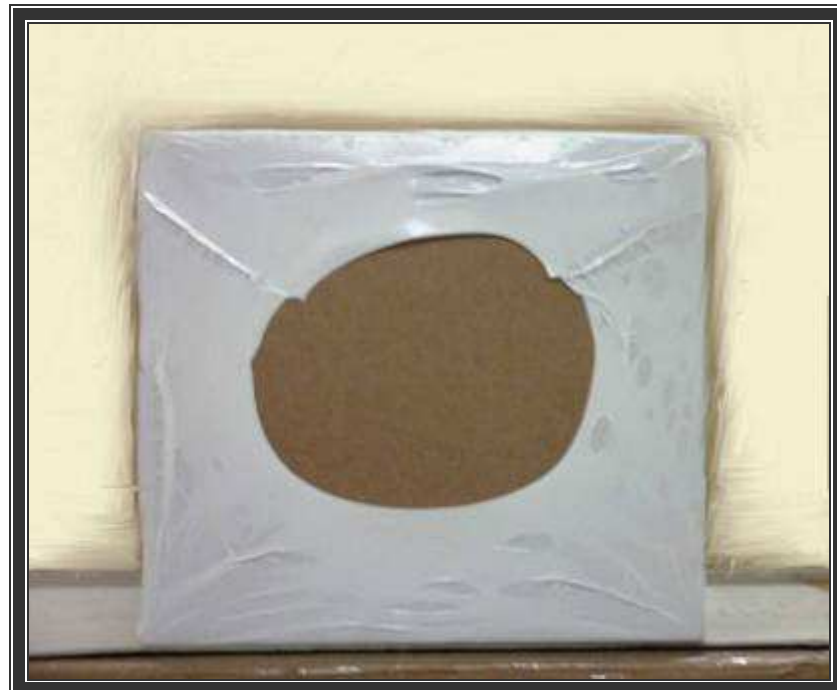

5.0 Licence Plate requirements

TBS and Random House with cooperation from BIC now have introduced a Licence Plate system that is less labour intensive and faster than the standard process used currently.

It involves a close partnership between the printer and TBS, and in turn benefits all parties including the Publisher.

The licence Plate is a barcode system which carries all the relevant information to process the delivery. The barcode incorporates what is on a pallet and the dimensions of both the book and pack.

The breakdown of the information in the licence plate is as follows

- **ISBN**
- **Unique pallet identification number**
- **Number of packs on the pallet**
- **Pack amount**
- **Price**
- **Weight and dimensions of both the book and pack**

This information is sent from the printers into TBS electronically on a XML file using the BIC Printers Delivery Advice Note standard. (**Currently, v 1.0**)

The printers involved with the licence plate system so far are Clays and Bookmarque, but other printers are actively being taken on

Technical requirements

There are a number of technical requisites that need to be met before the Licence Plate system can be fully implemented. These involve the transfer of the data between parties, and the quantity of the data within the files.

Our preferred method of file delivery is via email to formate@tbs-ltd.co.uk

The email subject line must be 'Printers Delivery Advice Note'. Any other subject line will not be recognised and the email will not be processed.

The XML file should be sent as an attachment. Although multiple attachments can be sent, we would prefer one attachment per email for ease of management if problems do occur.

Licence Plate files are processed by the TBS I.T. department hourly, starting from 6:30 am until 5:30 pm, therefore we would expect to receive the data at least 1 hour before the stock arrives.

The TBS I.T. department operate a strict policy of 'non-interference' with data transfers. This means that any files which fail to process must be resent from the suppliers system, subject to the nature of the failure.

5.1 Licence Plate requirements

Whilst developing the partnership, your contact with the I.T. team will be through the Project Team assigned. Once the Licence Plate is live and signed off, all correspondence should be through our Helpdesk:-

Email: helpdesk@randomhouse.co.uk

Tel: 01206 255900

Warehouse requirements

A frequent issue with new suppliers is the quality of the data. Such as weights expressed in kilos instead of grams or vice-versa.

Non-ASCII characters in the data. Missing mandatory elements in the data.

Part of the take-on process will involve TBS checking sent data against physical shipment, and we will report back any discrepancies. However, it's important that data is consistent, as we are 100% reliant on the data being sent.

Another area that often fails is the weight and measures. These are sometimes calculations instead of measured within the warehouse. We would strongly recommend that new suppliers investigate a QC role at the very least during go-live, to ensure the metrics are accurate and meet our three percent tolerance requirements.

TBS cannot accept over-height pallets. (Maximum height 1100 mm from floor to pallet top) Any 'odds', miss counts, or failure to send the XML file will impede the processing of the Licence Plate deliveries.

When printers are using License plate it is essential that all binders pack labels must be to the BIC standard, that is code128, see Appendix 2, page 15

5.2 PALLETS

- 5.3 TBS operates its own pallet pool, into which many printers and binders have entered. The present participation list is attached. If you wish to join the pallet pool, please contact the TBS Goods-In dept.
Email address: goodsin@tbs-ltd.co.uk
Fax: 01206 255848 .
TBS pallets must only be used for deliveries into TBS.

If a printer/binder is not a pool participant, we expect deliveries to be made on pallets that meet the BS ISO 6780:2003. standard have four way entry and a full perimeter base with struts no less than 16 mm thick timber, and no less than 950mm wide on all four sides. The pallet must be made from solid wood, Plywood pallets are not, acceptable (See picture below of compliant pallet and Appendix 1 for further details).

- 5.3 Dimensions must measure 1200 mm x 1000 mm. The pallet height must be 150 mm including the pallet base and should not exceed 1100 mm for a loaded pallet in order to comply with TBS pallet racking configuration. The width of the timber struts should be no less than 950 mm across
- 5.4 **Pallets should not exceed a gross weight of 750 kg. (See Appendix 1).**
- 5.5 Priced product should not be mixed with unpriced product, and jacketed product should not be mixed with unjacketed product.
- 5.6 Where product requires re-palletising or inverting due to non-conformance the cost of such activity will be charged according to the TBS Schedule of Rates. (See Appendix 3).



6.0 DELIVERY VEHICLES

- 6.1 Deliveries made to our Frating Site should be capable of side unloading where possible. Suppliers must specify at the time of booking whether a vehicle will be rear or side unloading.
- 6.2 Pallets may be stacked two high at maximum but must be secured together with either shrink-wrap or banding. Metal banding may not be used. Where pallets are stacked during transit they must be sufficiently protected to ensure that product is not damaged. Product showing obvious signs of compression damage may be rejected at this stage.
- 6.3 Under no circumstances will palletised loads that are stacked in a pyramid fashion be unloaded and any load considered by the Goods In Supervisor, Manager or Site Safety Officer to be unsafe will be rejected. TBS will not accept any responsibility for commercial impact of load rejection for the above reasons. No load will be moved using rope or strapping

7.0 POINT OF SALE

- 7.1 The following requirements apply to the supply of Point of Sale product (hereafter referred to as POS) to TBS.
- 7.2 All POS is to be supplied in packs or bundles of complete sets. Sets for dumpbins, counter packs or similar must contain all components of dumpbins including outers in ready to use format.
- 7.3 POS bundles or packs are to be labeled with full details of ISBN, bar code, descriptions, quantity, price, weight and publisher/supplier details. (See Appendix 2) It should be noted that the details for empty items should relate to the ISBN for the empty items.
- 7.3 All POS is to be accompanied by a delivery note containing ISBN and full product details including quantities. (Refer to section 2.2 for details).
- 7.4 Any small deliveries made via third party courier do not need to be booked in but they must arrive between 08.00 and 16.00 hrs. They will need to be correctly addressed and accompanied by an appropriate delivery note.
- 7.5 Posters, headers, mobiles and promotional material will not be considered non compliant if there is no barcode. Posters should have an eye readable isbn as part of the art work.
- 7.6 Palletisation of product must be on pallets sized 1000mm x 1200mm with maximum pallet height of 1100mm. (See Appendix 1).
- 7.7 For posters, headers, mobiles and promotional material, where the quantities are less than one pallet, items may be mixed on a pallet.

- 7.8 Any oversized or ready assembled products such as Spinners require 7 days notice of delivery and specific details of the nature of the product must be given to ensure that appropriate offloading and storage facilities can be provided.
- 7.9 All oversized or ready assembled products such as Spinners are to be supplied with adequate packaging for onward despatch to individual customers by TBS carriers.
- 7.10 Outers supplied for dumpbins, counter packs or similar must be of the correct dimensions and of suitable quality to accommodate full and made up items and any fillers required must be provided so as to limit movement and avoid damage.
- 7.11 Dumpbins must be supplied on a pallet together with their outers, as opposed to outers supplied on a separate pallet.
- 7.12 All products that require assembly by either TBS or end users should be accompanied by an instruction sheet for assembly.
- 7.13 Any item delivered with a selling unit of more than one should be securely packaged in unit groups. Both the packaging and the paperwork should clearly identify the product as a multiple part unit. For example, leaflets sold as unit size 25 must be clearly packaged in groups of 25. If there were in total 100 leaflets the pack should indicate that it contains 4 units of stock.
- 7.14 Stickers (sheets or rolls) are to be identified as a unit (as opposed to the sticker itself) on both the packaging and the paperwork.

8.0 HEALTH AND SAFETY

- 8.1 All POS or binders packs must clearly display their weight.
- 8.2 No pack should weigh in excess of 16 kg.
- 8.3 Any pack containing unevenly distributed weight must be clearly identified as such.
- 8.4 **Pallets should not exceed maximum gross weight of 750 kg.** (See Appendix 1).
- 8.5 **Pallets should comply with the pallet specification as detailed in Appendix 1. This is with particular reference to the floor struts of the full perimeter base which allow the weight of the pallet to be distributed evenly. The pallet must be made from solid wood, Plywood pallets are not, acceptable**
- 8.6 Drivers are not to enter the warehouse due to safety requirements and security.

9.0 **GENERAL**

- 9.1 TBS has a no smoking policy in and around the sites. Drivers may smoke in the cabs of their vehicles and nowhere else.
- 9.2 A wash room facility exists for drivers in the TBS Goods In Reception office.
- 9.3 Drivers are expected to carry their own forms of communication and will not normally be allowed to use the TBS telephone system.
- 9.4 No overnight parking facilities are available on site.
- 9.5 The on-site speed limit is 10 mph /16 kph.
- 9.6 All drivers are expected to follow the site signage and to park up in the bays marked until given instructions for unloading bay allocation.
- 9.7 Drivers are not to enter the warehouse.
- 9.8 Vehicles may be stopped and searched when they leave the site at the managements discretion.

B SITE ADDRESSES

Frating Distribution Centre

Frating Distribution Centre
TBS Ltd
Colchester Road
Frating Green
Near Colchester
Essex
CO7 7DW

Goods In Phone: 01206 255804

Fax: 01206 255848

E-mail: goodsin@tbs-ltd.co.uk

Brantham Warehouse

TBS Ltd
Factory Lane
Brantham
Manningtree
Essex
CO11 1NW

Phone: 01206 290420

Fax: 01394 290430

Note: Requires curtain sided vehicles for side unloading.

C TBS PALLET POOL PARTICIPANTS

Activsea
Antony Rowe
APPL
Biddles
Bookbridge
BookMarque
Butler & Tanner
Clays
Codex
Cox & Wyman
Karl king
L & T
Mackays
MPG
Parragon
Publiship
Sound Performance
T.J. International
Victoria Litho
W.M Clowes

Appendix 1
PALLET SPECIFICATION

All deliveries should be made on pallets. All pallets should conform to the requirements listed in the specification. Overall pallet dimensions will be:

- 1200mm x 1000mm x 150mm. **Timber thickness must no be less than 16mm x 950 mm width**
- The maximum overall height for a loaded pallet is not to exceed 1100mm including the pallet.
- The maximum gross weight of a pallet is not to exceed 750 kg.
- The maximum permissible overhang on any face of a pallet is not to exceed 50mm.
- The pallet should have four-way entry, and have a full perimeter base. Pallets Standard must be **BS ISO 6780:2003**. The pallet must be made from solid wood, Plywood pallets are not, acceptable
- Please note the floor struts on all four sides of the full perimeter base – see diagram below. This gives the pallet strength and is necessary for health and safety reasons.
- Goods are to be packed a single title to a pallet, all pallets of the same title must be of a consistent quantity with the exception of the last make up pallet which should be clearly identified.
- Small quantities of product that need to be mixed on a pallet should ideally be by layer and separated by a cardboard divider. The pallet should be shrink-wrapped and clearly identified as mixed.

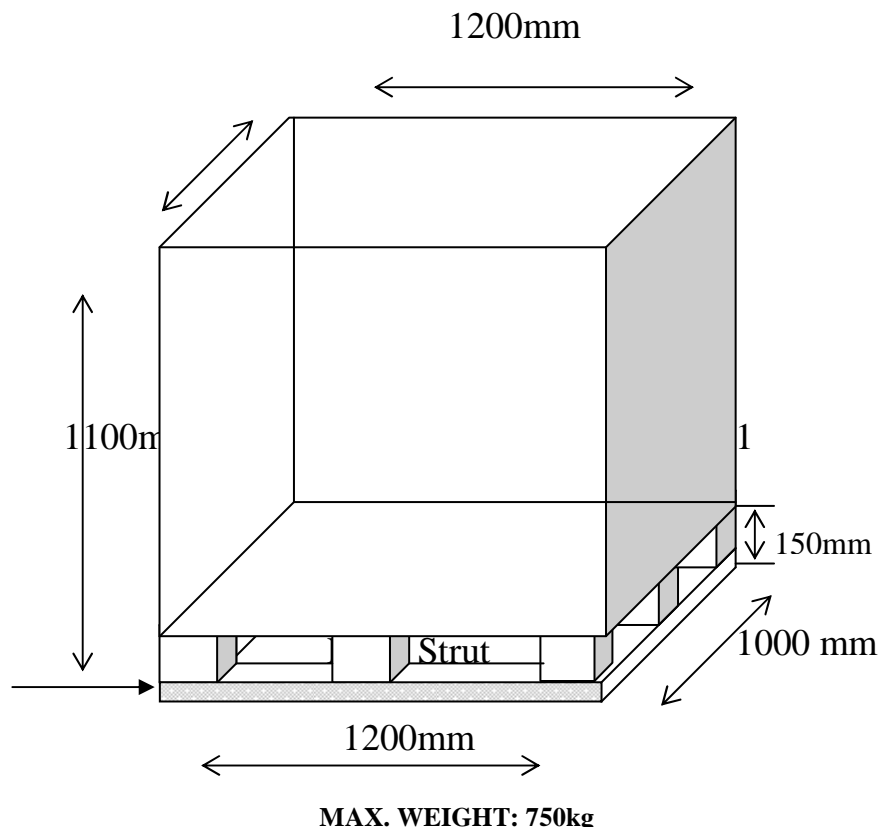

Appendix 2

BINDER'S PACK IDENTIFICATION REQUIREMENTS

List of data requirements and their source.

Data	Source	Representation
Publisher's name	Publisher	Eye readable
Printer's name	Printer	Eye readable
ISBN in its standard format	Publisher	Eye readable
EAN-13 article number	Derived from ISBN	Bar code
Book title	Publisher	Eye readable
Price / Currency	Publisher	Bar code and eye readable
Quantity in binder's pack	Printer (generally)	Bar code and eye readable
Weight of pack	Printer	Eye readable

- Currency to be based on ISO 4127
- Label size should be A6 (148 mm wide by 105 mm high). Labels may be curved or square cut at the corners.
- Labels should be white with black detail normally but other contrasting colours are acceptable, providing clarity and bar code scanner readability is maintained.
- Details of how to produce a barcode can be found in the extract from the Book Industry Communication Binder's Pack Bar Code Label Standard spec. (See Appendix 4). Further information can be obtained from their web site on www.bic.org.uk.
- Example of label layout is re-produced below:

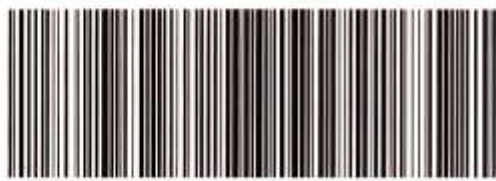
Publisher: TBS Distributio	Price: 5.99
Title: BAR – CODE LABEL	Qty: 20
Author: A N OTHER	Pack WT: 15.00 Kg
ISBN: 0 – 09136 – 230 – X	
PRINTER'S NAME	
	
<small>(02)09700091362300(37)0020(90)1205.99GBP</small>	

Appendix 3.

SCHEDULE OF RATES

Task	Rate	
	Low Volume (1-130)	High Volume (131+)
	Per Unit	Per Unit
Minimum fee (charged per job)	£30	na
Sticker Binder's Packs/ POS Material with TBS barcode label	min fee £30.00 + 0.23 for each label above 130 labels	£0.23
Supply labels only		£0.06
Supply cartons for repacking	£1.34	£1.34
Task	Rate per Hour	Rate per Pallet
Recharges for rectifying non-compliance	£20.38	na
Supply pallets for handballing and inverting	£20.38	£10 per pallet

- These charges are in addition to the [£150.00](#) standard charge for non-compliance.
 - Please note that this Schedule of Rates will be subject to change.
Hourly rate as from July 1st 2009 is now £20.38
- Where instances of non-compliance are pre-advised they will be dealt with according to management discretion.

Issues Sheet

Date	Version	Change/Comment	By
11/08/97	1.0	First issue at Frating	KM
22/08/97	1.1	Mannintree phone, page nos. corrected and Section 5.0 and 2.00 amended and 6.0 added.	KM
16/04/99	1.2	Telephone nos. Frating amended. Added POS page and H+S Section 8.	KM
23/08/00	1.3	Document reformatted and sections re-numbered. Introduction Section (1) and an Index added. Reference to non-conformance penalties added (1). Booking-In Section (2) amended to include details of documentation required. Binder's Pack section added (4). Details of Tiptree site removed. Pallet pool updated. Draft copy only.	AR
22/02/01	1.4	Standard charge for non-compliance introduced. Schedule of rates added as Appendix 3. Binder's pack (4) and Pallet (5) sections made more comprehensive. POS section (7) made more comprehensive.	AR
18/07/01	1.4	Updated hourly rate of £19.21 in schedule of rates.	AR
08/10/01	1.5	Added Brantham Warehouse address. BIC binder's pack bar code label standard specification added as Appendix 4.	AR

Application for TBS pallet Pool

Terms and conditions

TBS will supply your Company with pallets

We can either supply you with an agreed quantity and you can have a replacement quantity each time you deliver, or a bulk quantity, and you can pick up a full load when your stock holding depletes.

The cost of collecting the pallets is at your expense.

Your Company are responsible for the quantity received from and delivered to TBS

A count must be kept so that all TBS pallets are accounted for.

Lost pallets will be replaced at cost, £10.00 per pallet.

The TBS pallets are to be used exclusively for TBS deliveries.

If you run out of TBS pallets you must use compliant pallets for your delivery into TBS as set out in the inbound document.

Notice of a pallet pick up must be given 24/48 hours in advance.

Only good quality TBS pallets are to be used when supplying Stock to TBS.

Any pallet that is damaged is to be sent back to TBS for repair.

Please tick the appropriate box to inform us as to what method of collection you prefer.

Replacement collection

Bulk collection

To accept terms and conditions please sign this document and return the form to

TBS
Goods In
Frating Green
Colchester Road Frating
CO7 7 DW

Sign _____.

Print _____.

Date _____.

Any queries please contact David A Russell

Email drussell@tbs-ltd.co.uk

Phone 01206 255852